

SYMB	REVISION	DATE	APVD.	SYMB	REVISION	DATE	APVD.	VERSION: 2	F2A-11-1/1	
								MODE	Tactile Feedback	
								TIMING		
								LINE(S)	CIRCUIT	STROKE
								1	1P1T	0.15

Without any banned substance! Compliance with RoHS!

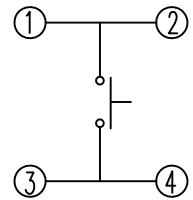

CIRCUIT DIAGRAM

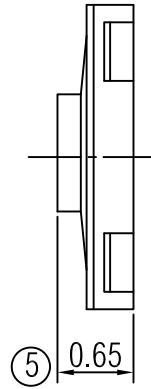
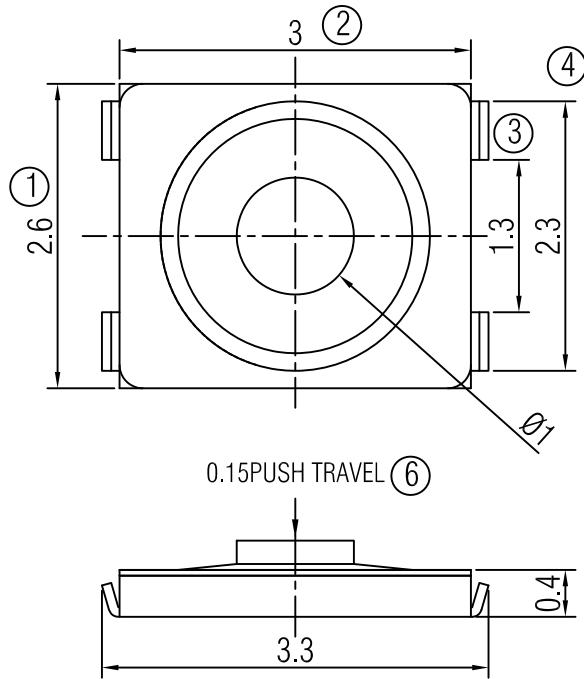
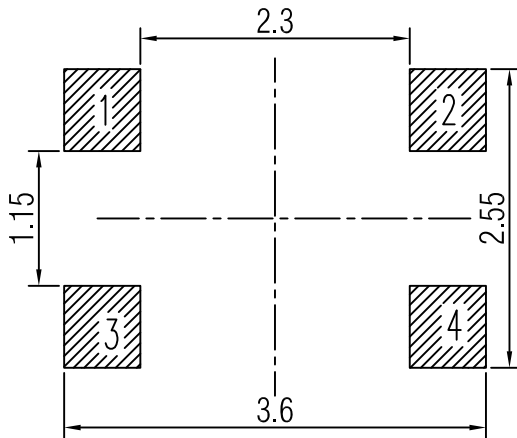

Recommended PAD Layout ± 0.05
TOP VIEW

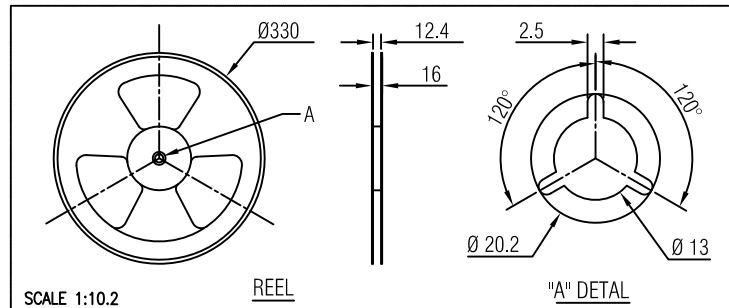

SCALE 1:10.2

REEL

"A" DETAIL

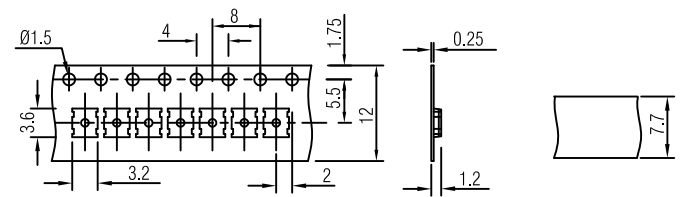

SCALE 1:2:1

CARRIER TAPE

COVER TAPE

PACKING DETAIL

<QTY:5000PCS/REEL>

TYPE	TACT SWITCH		UNIT	mm	9				
SERIES	TSKH-036511		SCALE	14:1	8				
PART NO.	TSKH-036511-		DATE	12/03/07	7				
SPEC. NO.	SETD01660-01		PAGE	1/6	6				
DRAWN	CHECKED	APVD.	TOLERANCE		5				
			ANGLE	$\pm 3^\circ$	4	TERMINAL 1,2,3,4	PBS	4	Ag PLATED
			UP TO 1	± 0.1	3	STEM	SILICA GEL	1	NATURE
			ABOVE 1 ~ 5	± 0.2	2	CONTACT	SUS	1	Ag CLAD
			ABOVE 5 ~ 50	± 0.3	1	CASE	LCP	1	BLACK
SANWIN ELECTRONIC TECHNOLOGY CO. LTD.					NO.	NAME	MATERIAL	QTY.	FINISHING